



DTR.PCE.PRE-28(ENG)

APLISENS

MANUFACTURE OF PRESSURE TRANSMITTERS
AND CONTROL INSTRUMENTS

USER'S MANUAL

PRESSURE TRANSMITTERS

PCE-28

DIFFERENTIAL PRESSURE TRANSMITTERS

PRE-28





HYDROSTATIC LEVEL PROBES

PCE-28P

WARSAW MAY 2009

APLISENS JSC 03-192 Warszawa, ul. Morelowa 7
tel. +48 22 814 07 77; fax +48 22 814 07 78
www.aplisens.pl, e-mail: aplisens@aplisens.pl

Symbols used

Symbol	Description
	Warning to proceed strictly in accordance with the information contained in the documentation in order to ensure the safety and full functionality of the device.
	Information particularly useful during installation and operation of the device.
	Information particularly useful during installation and operation of a type Ex device.
	Information on disposal of used equipment

BASIC REQUIREMENTS AND SAFE USE

- The manufacturer will not be liable for damage resulting from incorrect installation, failure to maintain the device in a suitable technical condition, or use of the device other than for its intended purpose.

- Installation should be carried out by qualified staff having the required authorizations to install electrical and pressure-measuring devices. The installer is responsible for performing the installation in accordance with these instructions and with the electromagnetic compatibility and safety regulations and standards applicable to the type of installation.

- In systems with pressure transmitters there exists, in case of leakage, a danger to staff on the side where the medium is under pressure. All safety and protection requirements must be observed during installation, operation and inspections.

- If a device is not functioning correctly, disconnect it and send it for repair to the manufacturer or to a firm authorized by the manufacturer.



In order to minimize the risk of malfunction and associated risks to staff, the device is not to be installed or used in particularly unfavourable conditions, where the following dangers occur:

- possibility of mechanical impacts, excessive shocks and vibration;
- excessive temperature fluctuation, exposure to direct sunlight;
- condensation of water vapour, dust, icing.



Installation of intrinsic safety versions should be performed with particular care, in accordance with the regulations and standards applicable to that type of installation.



The manufacturer reserves the right to make changes (not having a negative impact on the operational and metrological parameters of the products) without updating the contents of the technical manual

1. INTRODUCTION	6
2. USER MATERIALS	6
3. APPLICATIONS AND MAIN FEATURES	6
4. IDENTIFYING MARKS. ORDERING PROCEDURE	6
5. TECHNICAL DATA	7
<u>5.1. PCE-28. TECHNICAL DATA</u>	7
5.1.1. PCE-28. MEASUREMENT RANGES	7
5.1.2. PCE-28. METROLOGICAL PARAMETERS	7
5.1.3. METROLOGICAL PARAMETERS PCE-28 FOR PED VERSION.	7
<u>5.2. PRE-28. TECHNICAL DATA</u>	7
5.2.1. PRE-28. MEASUREMENT RANGES	7
5.2.2. PRE-28. METROLOGICAL PARAMETERS	7
<u>5.3. PCE-28, PRE-28.- COMMON PARAMETERS</u>	8
5.3.1. PCE-28, PRE-28 . ELECTRICAL PARAMETERS	8
5.3.2. PCE-28, PRE-28. PERMITTED ENVIRONMENTAL CONDITIONS	8
5.3.2. PCE-28, PRE-28. CONSTRUCTION MATERIALS	8
<u>5.4. PRESSURE CONNECTORS</u>	8
5.4.1. PCE-28. PRESSURE CONNECTORS.....	8
5.4.2. PRE-28. PRESSURE CONNECTORS.....	8
<u>5.5. PCE-28, PRE-28. ELECTRICAL CONNECTORS AND INGRESS PROTECTION RATING OF CASE</u>	9
6. CONSTRUCTION	9
<u>6.1. MEASUREMENT PRINCIPLES</u>	9
<u>6.2. CONSTRUCTION</u>	9
<u>6.3. CASING, ELECTRICAL CONNECTIONS</u>	9
7. PLACE OF INSTALLATION OF TRANSMITTERS	9
<u>7.1. GENERAL NOTE</u>	9
<u>7.2. LOW AMBIENT TEMPERATURE</u>	10
<u>7.3. HIGH MEDIUM TEMPERATURE</u>	10
<u>7.4. MECHANICAL VIBRATION, CORROSIVE MEDIA</u>	10
8. INSTALLATION AND MECHANICAL CONNECTIONS	10
9. ELECTRICAL CONNECTION	11
<u>9.1. GENERAL RECOMMENDATIONS</u>	11
<u>9.2. CONNECTIONS FOR TRANSMITTERS WITH PD-TYPE CONNECTOR</u>	11
<u>9.3. CONNECTIONS FOR TRANSMITTERS WITH PK OR PM12-TYPE CONNECTOR</u>	11
<u>9.4. CONNECTIONS FOR TRANSMITTERS WITH TERMINAL BOX (PZ-TYPE CONNECTOR)</u>	12
<u>9.5. PROTECTION FROM EXCESS VOLTAGE</u>	12
<u>9.6. EARTHING</u>	12
10. SETTING OF ZERO POSITION AND MEASUREMENT RANGE	12
11. SERVICES AND SPARE PARTS	13
<u>11.1. PERIODIC SERVICE</u>	13
<u>11.2. UNSCHEDULED SERVICES</u>	13
<u>11.3. CLEANING THE DIAPHRAGM SEAL, OVERLOADING DAMAGE</u>	13
<u>11.4. SPARE PARTS</u>	13
12. PCE-28P LEVEL PROBES.....	14
<u>12.1. APPLICATIONS</u>	14
<u>12.2. PCE-28P. TECHNICAL DATA</u>	14
<u>12.3. PRINCIPLES OF OPERATION, CONSTRUCTION</u>	14
<u>12.4. PLACE AND METHOD OF INSTALLATION, FITTING</u>	14
<u>12.5. ELECTRICAL CONNECTION. SETTINGS</u>	14
<u>12.6. EARTHING</u>	14
13. PACKING, STORAGE AND TRANSPORT	15
14. GUARANTEE	15
15. ADDITIONAL INFORMATION	15
16. FIGURES	15

I. APPENDIX EX

DTR.PCE.PRE-28(ENG)

Appendix Ex.02



PCE-28/XX/YY, PCE-28P/XX/YY PRESSURE TRANSMITTERS,
TYP PRE-28/XX/YY DIFFERENTIAL PRESSURE TRANSMITTER
Ex VERSIONS

1. Introduction

1.1. The "Appendix Ex.02" to DTR.PCE.PRE-28(ENG) applies to PCE-28/XX/YY, PCE-28P/XX/YY and PRE-28/XX/YY transmitters, marked on the rating plate as shown in 2.2 and 3. and signed "Ex" in the Product Certificate, only.

1.2. The appendix contains supplementary information relating to the Ex version transmitters.

During installation and use of the Ex transmitters, reference should be made to DTR.PCE.PRE-28(ENG) in conjunction with "Appendix Ex.02".

2. Using of PCE-28/XX/YY, PCE-28P/XX/YY and PRE-28/XX/YY transmitters in danger zones.

2.1. The PCE-28, PCE-28P and PRE-28 transmitters are produced in accordance with the requirements of the following standards: EN 60079-0:2004, EN 50303:2000, EN 60079-26:2007, EN 60079-11:2007, EN 61241-0:2006, EN 61241-11:2006

2.2. The transmitters may operate in areas where there is a risk of explosion, in accordance with the rating of the explosion protection design:



II 1/2G, Ga/Gb Ex ia IIC T4/T5/T6
I M1 Ex ia I
II 1D Ex ia D20 T105°C
KDB 08ATEX002X

3. Identifying marks

Intrinsically safe transmitters (Ex version) must have a rating plate containing the information specified in paragraph 4 of DTR.PCE.PRE-28(ENG) and also at least the following:

- CE mark and the notified unit number: 1453, mark
- designation of explosion protection design, certificate number
- values of parameters such as: Ui, Ii, Ci, Li
- type of electrical and process connectors
- manufacture year and serial number

4. User information.

Together with the transmitters, user will receive: User's Manual signed DTR.PCE.PRE-28 (ENG) with the Appendix Ex.02, and the Product Certificate.

5. Permissible input parameters (based on data from the KDB 08ATEX002X certificates and certification documentation).



The transmitters should be powered via the associated power supplier and measurement devices provided with the relevant intrinsic-safe certificates. The parameters of their outputs to the danger zone should not exceed the limit power supply parameters specified below for the transmitters:



The pressure transmitter is an intrinsic safety apparatus with level of protection "ia", when supply circuit have level of protection "ia".

- for power supply with a linear characteristic
Ui = 28V Ii = 0,1A

- for power supply with a "trapezoidal" and "rectangular" characteristic
Ui = 24V Ii = 0,08A

Input inductance and capacity: Ci = 40nF, Li = 0,9mH

Pi for all type of power supply - see Table 1

Table 1

Pi [W]	Δt [°C]	Tp [°C]	Temperature classification	Pi [W]	Δt [°C]	Tp [°C]	Temperature classification
1.5	24.7	55	T6	0.9	14.8	65	T6
		70	T5			80	T5
		80	T4 and Group I			80	T4 and Group I
1.2	19.7	60	T6	0.6	9.9	70	T6
		75	T5			80	T5, T4 and Group I
		80	T4 and Group I			1.5	24.7

Tp – temperature of enclosure of mounted transmitter (for example at tank) without power supply, determined for maximum ambient temperature

Special conditions for safe use:

- electrical installation of pressure transmitters shall comply with installation requirements of valid standard.

6. Supply examples.

6.1.- for power supply with a linear characteristic

Power supply with a “linear” characteristic may be e.g. a typical barrier with parameters
 $U_0=28V$ $I_0=0.093A$ $R_w=300\Omega$.

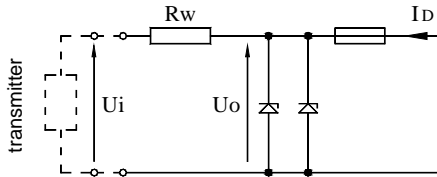

Fig.1. Power supply from a source with “linear” characteristic

6.2.-for power supply with a trapezoidal characteristic

Supply parameters according to the certificate:

a) $U_0=24V$ $I_0=0,08A$ $P_0=1,2W$

b) $U_0=24V$ $I_0=0.05A$ $P_0=0,6W$

Example of power supply from a source with trapezoidal characteristic (see Fig.2).

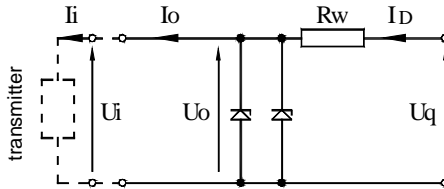

Fig.2. Power supply from a source with trapezoidal characteristic”

If $U_0 \leq \frac{1}{2} U_q$ then parameters U_q , I_0 , P_0 are interrelated as follows:

$$U_q = \frac{4P_i}{I_0}, \quad R_w = \frac{U_q}{I_0}, \quad P_0 = \frac{U_0(U_q - U_0)}{R_w}$$

6.3.-for power supply with rectangular characteristic

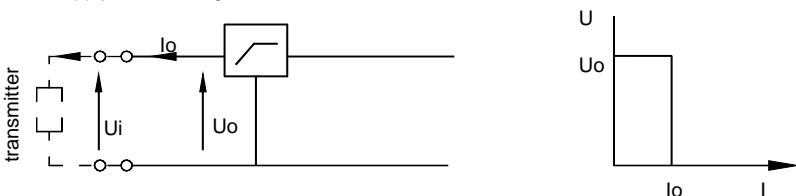

Fig.3. Power supply from a source with rectangular characteristic

$$U_0=24V \quad I_0=0,05A \quad P_0=1.2W$$

The supply of power from a source with a rectangular characteristic means that the voltage of the Ex power supply remains constant until current limitation activates.

The protection level of power supplies with a rectangular characteristic is normally "ib".

The transmitter powered from a such supply is also the Ex device with "ib" level protection.

Example of practical provision of power supply with a rectangular characteristic:

– use a stabilized power supply with $U_0=24V$, with the "ib" level protection and current limited to $I_0=50mA$.

Such current limit ensures that the power P_i not be exceeded ($0,05A \times 24V = 1,2W$)

and the powering of two transmitters simultaneously.

7. How to connect Ex transmitters: PCE–28, PCE–28P and PRE–28



The transmitter and other devices in the measuring loop should be connected in accordance with the intrinsic-safety and explosion-safety regulations and the conditions for use in dangerous areas.

Failure to observe the intrinsic-safety regulations can cause explosion and the resulting hazard to people.

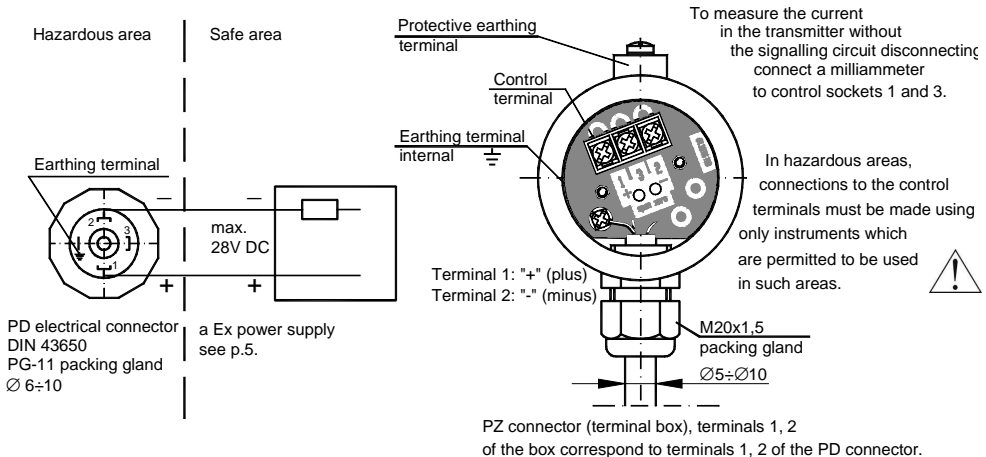

PD and PZ connectors are connected as above; the PK connector is connected as shown in Fig.1 in DTR.PCE.PRE-28 (ENG).

8. Basic requirements according to EN 50039 for type A and B leads used to connect the transmitter to the power supply and measurement circuit.

8.1. Thickness of insulation according to type of material, but not less than 0.2mm.

8.2. Insulation strength:



- $2U_N$ but not less than 500V AC for the wire;
- 500V AC between the cable screen and the connected wires;
- 1000V AC between two groups of wires, each of which contains half the connected wires of the cable.

8.3. Multiwire cable must not carry any circuit which is not an intrinsically safe circuit.

8.4. The cable must not carry circuits with a maximum voltage exceeding 60V.

8.5. The cables should be protected from damage, for example using channels, shielding pipes, cable racks, durable fastenings etc.



It is not allowed to repair or otherwise interfere with the transmitter's electrical circuits in any way.

Damage and possible repair can be assessed and done by the manufactures or another authorized party only.

1. INTRODUCTION

1.1. This user's manual is intended for **PCE-28** electronic pressure transmitters, **PRE-28** differential pressure transmitters and **PCE-28P** level probes users. Containing the data and guidelines necessary to understand the functioning of the transmitters and how to operate them. It includes essential recommendations concerning installation and use, as well as emergency procedures.

1.2. Complementary technical data for the **PCE-28** and **PRE-28** transmitters with diaphragm seal connectors and technical data for seals are contained in the catalogue cards "DIAPHRAGM SEALS".

1.3. The transmitters comply with the requirements of EU directives as shown on the plate and with the relevant Declaration of Conformity.

1.4. Additional data on **PCE-28**, **PRE-28** transmitters and **PCE-28P** probes in Ex versions covered by the common EC-type test certificate **KDB 04ATE002X** are contained in the appendix designated **DTR.PCE.PRE-28(ENG). Appendix Ex.02**.



During installation and use of **PCE-28**, **PRE-28** transmitters and **PCE-28P** probes in Ex version, reference should be made to **DTR.PCE.PRE-28(ENG)** in conjunction with **Appendix Ex.02**

1.5. The **PCE-28**, **PRE-28** transmitters are also made in a complies with the PED pressure version, meet the requirements for category IV, and then carry additional markings as in 4.3.

2. USER MATERIALS

Transmitters are delivered in single and/or multiple packs.

A transmitter is delivered together with a "Product Certificate" which is as a guarantee card also.

A batch of transmitters is supplied together with the User's Manual.

At the customer's request, a "Declaration of Compliance" and/or Certificate will be supplied.

(These documents are also published at the www.aplisens.pl)

3. APPLICATIONS AND MAIN FEATURES

3.1. The **PCE-28** pressure transmitters are designed to measure gauge pressure, vacuum pressure and absolute pressure of gases, vapours and liquids (including corrosive).

3.2. **PRE-28** differential pressure transmitters are used to measure liquid levels in closed tanks, and to measure differential pressure at filters, orifices and others.

PRE-28 differential pressure transmitters with P-type connectors are designed to work with static pressure of up to 4MPa only (see fig.7).

PRE-28 differential pressure transmitters with C-type vented connectors to mount together with a valve manifold are designed to work with static pressure of up to 16MPa (see fig.8).

3.3. The **PCE-28** can be fitted with a range of additional process connectors, enabling them to be used in a conditions variety, such as dense media, reactive media, high and low temperature etc.

Data on these connectors can be found in the catalogue cards "DIAPHRAGM SEALS".

To measure a medium which contains suspensions or impurities, or is viscous, hot, corrosive etc., use the **PRE-28** transmitter with a single diaphragm seal, or an **APRE-2000** smart differential pressure transmitter with a single diaphragm seal or an **APRE-2200** with a two diaphragm seals.

3.4. For depth measurements in open tanks, the transmitters are fitted with sensing modules with an extension tube, and are referred to as the **PCE-28P** level probes (for details see Section 12).

3.5. The **PCE-28** or **PRE-28** transmitters and the **PCE-28P** probes generate a 4...20mA signal using two-wire transmission, other **PCE-28** and **PRE-28** solution can be produced with 0...20mA or 0...10V signal using three-wire transmission.

4. IDENTIFYING MARKS. ORDERING PROCEDURE

4.1. Every transmitter and probe carries a rating plate containing at least the following information: CE mark, notified institutions numbers and certificates obtained designations, manufacturer name, type, serial number, measurement range, output signal, power supply voltage.

4.2. **PCE-28**, **PRE-28** and **PCE-28P** transmitters in Ex version, in accordance with the ATEX directive, have additional marks as described in **DTR.PCE.PRE-28(ENG) Appendix Ex.02** paragraph 3.



4.3. The rating plates of transmitters of type **PCE-28**, in versions compliant with the PED pressure directive contain the notified unit number 0062 next to the CE mark, as well as the designations of relevant certificate:

CE-PED- H1D-APL 001-04-POL

4.4. The designations to be used when ordering can be found in the Catalogue Cards.

5. TECHNICAL DATA

5.1. PCE-28. Technical Data

5.1.1. PCE-28. Measurement Ranges

The PCE-28 transmitter can be produced with any desired range in the interval:

0...10mbar÷0...1000bar (over pressure, under pressure)
400mbar ÷ 80bar (absolute pressure).

Recommended standard ranges:

over, under pressure (0÷ -1; -0,4; -0,1; 0,1; 0,4; 1; 2,5; 6; 10; 16; 25; 60; 160; 250; 400, 600, 1000) bar
absolute pressure (0 ÷ 0,4; 1; 2,5 6; 10; 16; 25; 60)bar

5.1.2. PCE-28. Metrological Parameters

Table 1	Measurement Range		
	100mbar (10kPa)	400mbar (40kPa)	0...1 ÷ 1000bar (0...100kPa ÷ 100MPa)
Overpressure limit (repeatable, no hysteresis)	1bar (100kPa)	2,5bar (250kPa)	4 x range max 1200bar (120MPa)
Damaging overpressure	2bar (200kPa)	5bar (500kPa)	8 x range, max 2000bar (200MPa)
Accuracy	0,3%	0,2%	(0,16 %- special version)
Thermal error	typically 0,3% / 10° C;	max 0,4% /10° C	typically 0,2% /10° C; max 0,3% /10° C
Long term stability	0,2 % / year	0,1 % / year	
Hysteresis and repeatability	0,05%		

5.1.3. Metrological Parameters PCE-28 for PED version.

PCE-28 transmitters, in the PED pressure directive versions, are produced with a measurement range in the interval from -1 bar to 400bar gage, or from 0 to 400 bar absolute, with the overpressure up to 440bar.

PCE-28 transmitters with the S-Mazut seal pressure connection, assembled with the PED version can be produced within the range -1bar to 100 bar gage, or within the 0 - 100bar absolute, and the overpressure up to 110bar. Other parameters are as given in Tables 1, except that the ambient temperature error is 7mbar/10°C. The value of the pressure measurement range and related overpressure are given on rating plate and at Product Certificate.

i

5.2. PRE-28. Technical Data

5.2.1. PRE-28. Measurement Ranges

The PRE-28 differential pressure transmitters are manufactured with any desired range in the interval 1,6mbar to 25 bar.

Recommended ranges: 0,4; 1; 2,5; 6; 10; 16; 25bar
(-0,1...0,1); (-1...1) bar

5.2.2. PRE-28. Metrological Parameters

Table 2	Measurement Ranges			
	100mbar (10kPa)	1bar (100kPa)	2bar (200kPa)	25bar (2500kPa)
Overpressure limit Static pressure limit	250bar (25MPa) [40bar (4MPa) for P-type connector]			
Accuracy	0,4%	0,25%		
Thermal error / 10°C	typical 0,3%, max 0,4%	typical 0,2%, max 0,3%		
Zero shift error for static pressure *	0,1% / 1MPa			
Hysteresis and repeatability	0,05%			

*- This error can be eliminated by zeroing the transmitter in static pressure conditions with zero differential pressure.

5.3. PCE-28, PRE-28.- Common parameters

5.3.1. PCE–28, PRE–28 . Electrical Parameters

Power supply for non-intrinsic-safe versions	10,5 ÷ 36V DC, rated 24V DC (for output signal 4 ÷ 20mA) 15 ÷ 30V DC- (for output signal 0÷10V, 0÷20mA)
Power supply for intrinsic-safe versions	in accordance with Appendix Ex.02.
Output signal	4 ÷ 20mA two-wire transmission 0 ÷ 10 V three-wire transmission 0 ÷ 20 mA three-wire transmission
Error due to supply voltage changes	0,005 % /V
Load resistance (for output signal 4÷20mA)	$R[\Omega] = \frac{U_{sup}[V] - 10,5V}{0,02A}$
Load resistance (for output signal 0 ÷ 10V)	R ≥ 5kΩ
Error due to supply voltage changes	0,005 %/V
Voltage for insulation strength testing	500 VAC or 750 VDC, see p.9.5.
Excess voltage protection	see p.9.5.

5.3.2. PCE–28, PRE–28. Permitted Environmental Conditions

Ambient temperature limit	-40 ÷ 80°C (for PCE-28)
Ambient temperature limit	-25°C ÷ 80°C (for PRE-28)

(Operating temperature range for intrinsic-safe versions in accordance with Appendix Ex.02)

Process temperature limit	-40 ÷ 120°C – direct measurement, over 120°C, only with the use of a diaphragm seal, radiator, looped siphon tube or impulse line.
Thermal compensation range	-10 ÷ 80°C (for PCE-28) or by arrangement
Thermal compensation range	0 ÷ 70°C (for PRE-28) or by arrangement
Relative humidity	0 ÷ 98%
Vibration during operation	max 4g
Exposure to direct sunlight	not recommended causing strong transmitter warming

5.3.2. PCE–28, PRE–28. Construction Materials

Diaphragm	Stainless steel 316L (00H17N14M2)
Sensing module	Stainless steel 316L (00H17N14M2)
Casing for electronic parts	Steel pipe, 304 (0H18N9)
PZ-type terminal box	Thick steel pipe, 304 (0H18N9)
Angular connector, DIN 43650, PD type	Itamide
Liquid filling the interior of the sensing module	Silicone oil, chemically inactive liquid for measurement of oxygen.
Cable shield in PK connector	Polyurethane, special version – teflon

5.4. Pressure Connectors

5.4.1. PCE–28. Pressure Connectors

M-type connector with M20x1.5 thread – see figure 3a
P-type connector with M20x1.5 thread – see figure 4a.
CM30x2 or CM20x1.5-type connector with flush diaphragm – see figure 5a.
RM-type connector with M20x1.5 thread and radiator.
G1/2 -type connector with G1/2" thread – see figure 6a
GP -type connector with G1/2" thread
CG1/2 -type connector with G1/2" thread and flush diaphragm – see figure 6c
CG1-type connector with G1" thread and flush diaphragm – see figure 6e
RG-type connector with G1/2" thread and radiator.
Seal connectors: see catalogue cards "DIAPHRAGM SEALS".

5.4.2. PRE–28. Pressure Connectors

P-type connectors with M20x1.5 thread – see fig. 7.
C-type connector to mount together with a valve manifold see fig. 8.
Diaphragm seal connectors: see the "Information Cards" for the diaphragm seals

5.5. PCE-28, PRE-28. Electrical Connectors and Ingress Protection Rating of Case

PCE-28, PRE-28 with PD-type connector, DIN 43650, PG-11 packing gland. IP67 rated (PN-EN 60529:2003)

PCE-28, PRE-28 with PZ-type terminal box, M20x1,5 packing gland. IP65 rated (PN-EN 60529:2003)

PCE-28, PRE-28, PCE-28P with PK-type cable connector. IP67 rated (PN-EN 60529:2003)

PCE-28 with PM12-type connector. IP67 rated (PN-EN 60529:2003)

6. CONSTRUCTION

6.1. Measurement Principles

The **PCE-28**, pressure transmitters, **PRE-28** differential pressure transmitters and the **PCE-28P** level probes operate by converting changes in the piezoresistive bridge, which are proportional to the measured pressure, into a standard current or voltage output signal.

The active sensing device is a silicon diaphragm with diffused piezoresistors, separated from the medium by an isolating diaphragm and manometric oil.

6.2. Construction

The basic component of the transmitter and probe is the sensing module, in which the input pressure is converted into an electrical signal. The sensing modules are fitted with pressure-transmitting connectors (see p. 5.4). The second element of the transmitter is an electronic unit which amplifies and standardizes the output signal. This is fitted with potentiometers which can be used to set the zero and the range positions.

For the measurement of dense, chemically reactive, or high-temperature media, the transmitters are fitted additionally with various types of diaphragm seal connectors, depending on the type of medium and environmental conditions (details can be found in the catalogue cards "DIAPHRAGM SEALS").

6.3. Casing, Electrical Connections

6.3.1. The casing of the **PCE-28** and **PRE-28** transmitters, made from $\varnothing 27$ pipe, is permanently mounted on the sensing module as shown in figure 1b and 7. On the other side is a **PD** type electrical connector with PG-11 packing gland. By unscrewing and removing the connector, can be gained access to the potentiometers used to the zero and range setting.

6.3.2. The **PCE-28, PRE-28** transmitters may be fitted with a **PK** cable connector (see figure 1c) or **PM12 (PCE-28 only)** (see figure 1f), mounted similarly to the **PD** connector. The body of the connector contains a permanently fixed and sealed cable of standard length 3m (other lengths can be produced to order). The cable contains a capillary which connects one side of the measuring diaphragm to the atmosphere.

6.3.3. The **PCE-28, PRE-28**, transmitters with a **PZ** type connector has a terminal box permanently mounted on the upper part of the casing (figure 2). The box is closed with a serrated lid and has an external earthing terminal. Mounted, on the inside, a terminal block equipped is with additional control terminals, galvanically connected to 1, 2 and 3 terminals. By connecting a milliammeter to sockets 1 and 3, a local measurement current can be made, without the need to disconnect the transmitter measuring circuit.

7. PLACE OF INSTALLATION OF TRANSMITTERS

7.1. General note

7.1.1. The **PCE-28** transmitters can be installed both indoors and outdoors. It is recommended that transmitters intended for outdoor use be placed in a box or under cover.

There is no need for a cover in the case of transmitters with **PZ** and **PK** type connectors.

7.1.2. The place of installation should be chosen in such a way as to allow access to the device and to protect it from mechanical damage. In planning the installation of the transmitter and configuration of the impulse lines, attention should be paid to the following requirements:

- The impulse lines should be as short as possible, with a sufficiently large cross-section, and free of sharp bends, in order to prevent blockages;
- Where the medium is a gas, the transmitters should be installed above the measuring point, so that condensation flows down towards the site of the pressure measurement; where the medium is a liquid or where a protective liquid is used, the transmitters should be installed below the place where the pressure measurement is taken;
- The impulse lines should be inclined at a gradient of at least 10cm/m;
- The levels of filling liquid in the impulse lines should be equal or kept constant difference,
- The configuration of the impulse lines and the valve connection system should be chosen with regard to the measurement conditions and to requirements such as the need to reset the transmitters in position and the need for access to the impulse lines during water or gas removal and flushing.





7.1.3. Where there is a risk of heavy objects hitting the instrument (resulting, in extreme cases, in a part of the system with transducers being torn off and medium leakage), appropriate means of protection should be applied for safety reasons and to avoid the possibility of sparking or other, more appropriate location should be selected for the transmitter.

7.2. Low Ambient Temperature



When the solidification point of the liquid whose pressure is being measured is greater than the ambient temperature, steps should be taken to protect the measurement apparatus from freezing effects.

This is particularly important in the case open-air installations.

Protection by filling the impulse lines with a ethylene glycol and water mixture, or another liquid whose solidification point does not exceed the ambient temperature is obtained. The transmitter case and lines thermal insulation protects from short exposure to low temperatures only. Where the temperature is very low, the transmitter and impulse lines should be heated.

7.3. High Medium Temperature.

The **PCE-28** and **PRE-28** transmitters may be used to measure media with temperatures of up to 120°C.

To protect the sensing module from temperatures in excess of 120°C, suitably long impulse lines are used to disperse the heat and to lower the temperature of the module.

Where it is not possible to use impulse lines of the required length, **PCE-28** transmitters with remote diaphragm seals should be used (see catalogue cards "DIAPHRAGM SEALS").



Data as per Appendix Ex.02 apply for the Ex version.

7.4. Mechanical Vibration, Corrosive Media.

7.4.1. Transmitters should correctly work with vibrations with amplitudes to 1,6 mm and accelerations to 4g. If strong vibrations are carried via the pressure line and disturb of measuring, use should be made of elastic pulse lines or transmitters with a remote diaphragm seal.

7.4.2. Transmitters should not be installed in places where the diaphragm, made of 316L steel (00H17N14M2), would be subject to corrosion by the medium being measured



If possible, transmitters with diaphragms made of Hastelloy C276 should be used, or other means of protection applied (e.g. in the form of a separating liquid) or transmitters with diaphragm seals adapted for measuring aggressive mediums according to catalogue cards "DIAPHRAGM SEALS") should be used.

8. INSTALLATION AND MECHANICAL CONNECTIONS

8.1. The **PCE-28** transmitters can be mounted directly on rigid impulse lines.

Where connectors are used as in figures 3a, 4a, 5a, 6a, 6c, 6e it is recommended that connection sockets be used as shown in figure.3b, 4b, 5b, 6b or 5c, 6d, 6f.

Where the connectors are as in figures 4a, 5a and 6c, 6e rectangular gaskets are used with each transmitter.

The socket shown as in figure 5c, 6d and 6f can be obtained from the manufacturer.

The material of the seal is selected based on the pressure value and the type and temperature of the medium.

If the pressure is applied via a flexible plastic tube, the transmitter should be mounted on a support with Red Ø6-M reduction.

In case of metal pipes, the used connections should comply with PN-82/M-42306.

The types of the impulse tubes are to be selected depending on the measured value of the pressure and the medium temperature.

8.2. The **PRE-28** transmitters can be mounted directly on rigid impulse lines.

To connect the basic versions of transmitters, with two M20 x 1.5 stubs (P-type connector), one can use (for example) straight connecting elements with nuts.

If the pressure is carried via a flexible plastic tube, use an reduction elements "Red Ø6-M" (M20x1,5 / Ø6).

The **PRE-28** transmitters can be installed using the Assembly Kit, on a ø25 pipe or on a flat surface using an angle bracket (figure 11).

The **PRE-28** with connecting cover (C-type connector) are designed for installation on 3-valve or 5-valve manifolds, to a 2" pipe or to a flat surface using an fastener C2 (figure 12) or "U" (figure 13). .

8.3. The **PCE-28** and **PRE-28** transmitters can operate in any position.

When installed on an object with a high-temperature medium, it is advantageous to mount the transmitter in a horizontal position with the packing gland pointing downwards or to the side, in such a way that the transmitter is kept away from the stream of rising hot air.

Examples of the use of Aplisens assembly components to isolate the **PCE-28** transmitters from high temperature media are shown in figure 14.

When the measurement range is small, the reading can be affected by the position of the transmitter and by the configuration of the impulse lines and the way in which they are filled with liquid.

This error can be corrected using the zero-setting function.

8.4. In selecting assembly components, it may be helpful to consult information on Aplisens connection elements, reduction elements, sockets, valves, reduction clamps and signal tubes.

Information on this subject can be found in the catalogue cards "FITTING ACCESSORIES".

Pressure may be transmitted to the installed device only after checking that it has a measurement range which properly corresponds to the value of the measured pressure, that gaskets have been properly selected and fitted, and the connector has been properly screwed tight.



Attempts to undo the screws or fixing connector pipes on a transmitter under pressure may cause the medium to leak and create hazards for the personnel.

When disassembling the transmitter, it is necessary to disconnect it from the process pressure or bring the pressure to atmospheric level, and to take particular care and precautions in case of media which are highly reactive, caustic, explosive or otherwise hazardous to personnel.

If necessary, rinse out this part of the system.

Transmitters with flange diaphragm seals are to be installed on the corresponding counter flanges on the facility.



It is recommended that the user matches the screw joints material to the pressure, temperature, flange material and seal to ensure tightness of the flange joint in the expected operating conditions.

Coarse-threaded screws complying with ISO 261 are to be used for flanges used in the transmitters.

Additional data concerning the diaphragm seals are specified in the catalogue cards "DIAPHRAGM SEALS".

9. ELECTRICAL CONNECTION

9.1. General recommendations

It is recommended that twisted pair cabling be used for the signal lines. If the transmitter and signal line are subject to a large amount of electromagnetic interference, then screened twisted pair cable should be used.

The signal wires should not run alongside network power supply cables or near to large electrically-powered devices.

The devices used together with the transmitters should be resistant to electromagnetic interference from the transmission line in accordance with compatibility requirements.

It is also beneficial to use anti-interference filters on the primary side of the transformers, the power supplies used for the transmitters and apparatus used in conjunction with them.

9.2. Connections for transmitters with PD-type connector.

The **PCE-28** and **PRE-28** transmitter and **PCE-28P** probe fitted with **PD** type connectors are to be connected as shown in diag.1a.

To make the connections, remove the terminal block from the contact pins together with its cover.

Then remove the block from its cover, levering it off with the end of a screwdriver inserted into the slot provided for this purpose. Connect the wires to the block.

Where the isolation of the wires in the packing gland is ineffective (for example, when single wires are used) the opening of the gland should be carefully sealed with an elastic sealing compound to obtain IP65 ingress protection. It is useful to form the segment of the signal wire leading to the PG-11 packing gland into a protective loop to prevent condensation from running down in the direction of the gland.



9.3. Connections for transmitters with PK or PM12-type connector.

The **PCE-28** and **PRE-28** transmitter with **PK** connector or **PCE-28** transmitter with **PM12** connector should be connected via a terminal box, in which the transmitter's cable is joined to the remainder of the signal line.

The terminal box must not be completely airtight, as the transmitter must be able to "breathe" through a capillary in the connector cable.

9.4. Connections for transmitters with terminal box (PZ-type connector).

The **PCE-28** and **PRE-28** transmitters with **PZ**-type connectors should be connected by linking the signal wires to a terminal block, as shown in figure 2. Carefully screw in the cover and cork of the packing gland, making sure that the wire is tightly packed. Where necessary, the packing gland should be further sealed as described in 9.2.

9.5. Protection from excess voltage

9.5.1. The transmitters and probes may be in danger from excess voltage caused by connection faults or atmospheric electrical discharge.

Protection from excess voltage between the wires of the transmission line is provided by TVS diodes installed in all types of transmitter (see the table, column 2).

9.5.2. In order to protect against excess voltage between the transmission line and the casing or earth (not prevented by the diodes connected between the transmission wires), additional protection is provided in the form of plasma surge arresters (see the table, column 3).

Also external protective devices may be used, e.g. the UZ-2 Aplisens system, or others. When the transmission lines are long, it is advantageous to use one protective device near the transmitter (or inside it), and another near entry points to devices used in conjunction with it.

Internal protection of transmitters and probes:

Table 3

	1	2	3
	Type of transmitter (probe) and type of electrical connector	Protection between wires (TVS diodes) – permitted voltage	Protection between wires and earth and/or casing – type of protection, permitted voltage
1	PCE-28, PRE-28 with PZ connector	39V DC	Plasma surge arresters - 100VDC
2	PCE-28 with PD, PK or PM12 connector	39V DC	Installed by arrangement
3	PCE-28P with PD, PK connector	39V DC	Installed by arrangement
4	PRE-28 with PD connector	39V DC	Installed by arrangement

9.5.3. The voltage in the protective elements must not exceed the maximum permitted values given in columns 2 and 3 of the table.

i The insulation test voltages (500V AC or 750V DC) given in 5.1.1 refer to transmitters plasma surge arresters - such protection is not used in Ex versions of transmitters.

9.6. Earthing

The methods of earthing the transmitters are shown in figures 1a, 2.

If the transmitter has, via a connector, a reliable galvanic connection with a properly earthed metal pipe or tank, additional earthing is not necessary.

10. SETTING OF ZERO POSITION AND MEASUREMENT RANGE

The transmitter is factory regulated for the measurement range stated in the order.

After it has been installed, it may become necessary for the zero position to be changed

The way of gaining access to the control knob is described in 6.3.

To perform the regulation, connect and power the transmitter in accordance with its technical parameters.

Supply a pressure equal to the lower limit of the measurement range, and make the output signal equal to 4mA (0mA, 0V) by turning the “zero” potentiometer. Turn the knob to the right to increase the output signal.

After the zero position has been set, supply a pressure equal to the upper limit of the range, and use the “range” potentiometer to make the output current (voltage) equal to 20mA (10V).

Recheck the zero position, and repeat the procedure if necessary.

i Potentiometers can be used to shift the zero position and the range by up to 10%, without altering the setting.

i The **PCE-28** and **PRE-28** transmitters with output signal $0 \div 10V$ not attain precisely 0V position.

11. SERVICES AND SPARE PARTS.

11.1. Periodic service

Periodic service should be made in accordance with the regulations to which the user is subject. During inspection, the pressure connectors should be checked for loose connections and leaks, the electrical connectors should be checked with regard to tightness and the state of the gaskets, and the diaphragm seals should be checked for tarnishing and corrosion. The conversion curve should also be verified.

11.2. Unscheduled services

If the transmitters or probes are installed in a location where they may be exposed to mechanical damage, excess pressure, hydraulic impulses or excess voltage, or the diaphragm may be in danger from sedimentation, crystallization or erosion, inspections should be carried out as required.

 The diaphragm should be inspected and cleaned, the protective diodes should be checked for shorting, and the conversion curve should be verified.

Where it is found that the signal in the transmission line is absent or its value is incorrect, a check should be made on the line and its terminal connections. Check whether the values of the supply voltage and load resistance are correct. If the line is in order, check the operation of the transmitter.

After checks have been made, take steps to eliminate the faults detected.

11.3. Cleaning the Diaphragm Seal, Overloading Damage

11.3.1. Sediment and dirt which have formed on the diaphragm in the course of operation must not be removed by mechanical means, as this may damage both the diaphragm and the transmitter itself. The only permitted method is the dissolving of sediment.

11.3.2. Sometimes transmitters malfunction due to damage caused by overloading, e.g. in case of:



- application of excessive pressure;
- freezing or solidification of the medium;
- action of a hard object, such as a screwdriver, on the diaphragm.

Usually in such cases the symptoms are such that the output current falls below 4mA or rises above 20mA, and the transmitter fails to respond to input pressure.

11.4. Spare parts.

The following transmitter parts may need replacing due to damage or normal wear:

PD connector – terminal block with angular cover and seal, connector base with seal, rating plate, case.

PK connector – the entire connector.

PZ connector – cover seal and packing gland.

In the Ex version, the user may replace only the terminal block with angular shield and the seal in the PD connector, or the seal and packing gland in the PZ connector.

 Other parts, due to their special characteristics and anti-explosive requirements, may be replaced only by the manufacturer or an authorized firm

12. PCE-28P LEVEL PROBES

12.1. Applications

The **PCE-28P** level probes are designed to measure the depth of medium in a tank which is accessible from the top. They can also be used to measure levels in open tanks, watercourses, canals, measurement pipes of open channels, to measure levels of liquid waste etc.

The **PCE-28P** probes have PZH certificates and can be used with food products.

12.2. PCE-28P. Technical Data

12.2.1. The **PCE-28P** probes are manufactured with measurement ranges in the interval 200÷3000mm H₂O.

12.2.2. PCE-28P. Metrological Parameters

	Measurement range	
	0...200÷500mm H ₂ O	0...700÷3000mm H ₂ O
Accuracy	0,25%	0,16%
Thermal error of zero	typically 0,3%/10°C, max 0,5%/10°C	typically 0,2%/10°C, max 0,3%/10°C
Thermal error of span	typically 0,2%/10°C max 0,3%/10°C	typically 0,2%/10°C max 0,3%/10°C
Hysteresis, repeatability	0,05%	

12.2.3. PCE-28P electrical parameters see p. 5.5.

12.2.4. PCE-28P permitted environmental and operating conditions:

Thermal compensation range	0÷25°C – standard -10÷70 – special version
Medium temperature	-25÷80°C
Other parameters	as given in 5.3. and 5.4.

12.3. Principles of Operation, Construction

The **PCE-28P** level probes work by converting the pressure of a column of liquid into a standard electrical signal. The **PCE-28P** generate 4÷20mA output signals with two-wire transmission, although a special version can produce 0÷20mA or 0÷10V signals with three-wire transmission.

The probe consists of a sensing module and an electronic assembly, connected with an extension tube whose length depends on the depth being measured. The tube can be fitted with a flange for mounting on the cover of the tank (figure 8). The **PCE-28P** probe can be fitted with PD and PK type connectors, (the connectors are shown on figures 1b, 1c, 9).

12.4. Place and method of installation. Fitting

The level probes are installed in places where liquid levels are to be measured, as described in 12.1.

The probe is immersed in the medium being measured, but the electronic assembly and connector should remain above the maximum level of the medium. When installing the probe, the zero position should be precisely determined. When the tube is particularly long, it should be fastened at two points. When the probe is installed in the open air, a roof or box should be used to cover the electronic parts. If there is a current or turbulence in the place where the probe will operate, a protective tube should be fitted.

 The medium around the sensing module should not be allowed to freeze. This applies particularly to water when the probe is used in the open air. The sealing diaphragms should be checked regularly, and sediment deposits, blockages etc. should not be allowed to occur.

Dirt should be removed only by dissolving or washing off.

12.5. Electrical connection. Settings

12.5.1. The **PCE-28P** probe should be connected as shown in figure 1a.

The probes are factory set to the range specified in the order.

The user may adjust the setting within the range 10% using the zero and range potentiometers.

12.5.2. The probes are protected against excess voltage as described in 9.5.

12.6. Earthing.

PCE-28P probes with PD and PK connectors, if excess voltage protection is fitted, the probe's extension tube should be earthed.

PCE-28P probes with PZ connectors should be earthed via the external earth terminal.

13. PACKING, STORAGE AND TRANSPORT

13.1. The transmitters should be packed singly or in sets, in such a way as to protect them from damage during transportation.

The transmitters should be stored in multiple packs under cover, in a place free of vapours and reactive substances, with an air temperature between +5°C and +40°C, and relative humidity of not more than 85%.

Transmitters with uncovered diaphragm or seal connectors, stored without packaging, should have covers to prevent damage to the diaphragm.

During transportation, the transmitters should be packed and secured so as to prevent them from shifting.

Any means of transport may be used, provided direct atmospheric effects are eliminated.

13.2. The **PCE-28P** probes are individually packed. Individually packed probes are bound in packages containing several probes. Storage and transport as above.

14. GUARANTEE

14.1 The manufacturer guarantees the proper operation of the **PCE-28** transmitters for a period of 24 months from the date of purchase and servicing provided under the guarantee and following the guarantee period. In the case of special versions, the guarantee period shall be agreed by the manufacturer and the user, but shall not be less than 12 months.

14.2. The manufacturer guarantees the proper operation of the **PCE-28P** probes for a period of 12 months, as well as servicing provided under the guarantee and following the guarantee period.

15. ADDITIONAL INFORMATION

The manufacturer reserves the right to make constructional and technological changes which do not lower the quality of the transmitters and probes

15.1. Related documents

Catalogue Cards "Diaphragm seals"

15.2. Related standards

PN-EN 60529:2003	Degrees of protection provided by enclosures (IP Code)
PN-EN 61010-1:2004	Safety requirements for electrical equipment for measurement, control and laboratory use. General requirements
PN-82/M-42306	Screwed connectors of pressure gauges
PN-81/M-42009	Automatics and industrial measurements. The packing, the storage and transport of devices. General requirements
PN-EN 1092-1:2004 (U)	Flanges and their joints – Circular flanges for pipes, valves, fittings and accessories. – Part 1: Steel flanges.

16. FIGURES

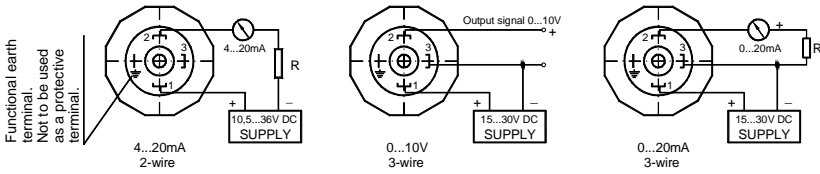

Fig.1a. Wiring diagram for PCE-28, PRE-28 transmitters and PCE-28P probe
(Not applicable to Ex version)

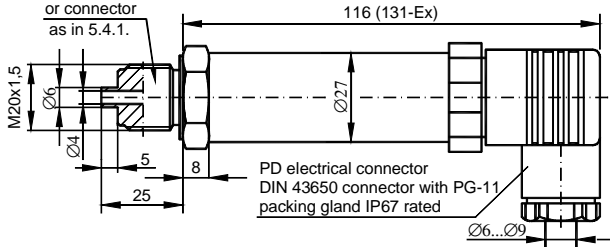

Fig.1b. PCE-28 transmitter with PD connector

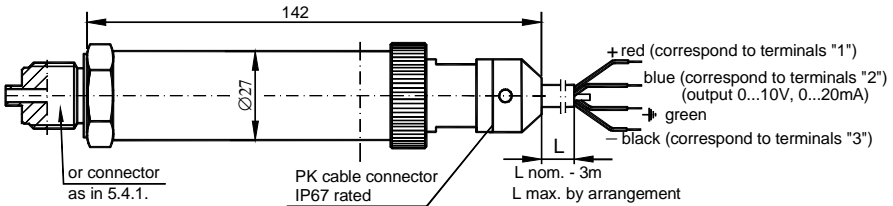

Fig.1c. PCE-28 transmitter with PK connector - (three-wire transmission 0...10V or 0...20mA).

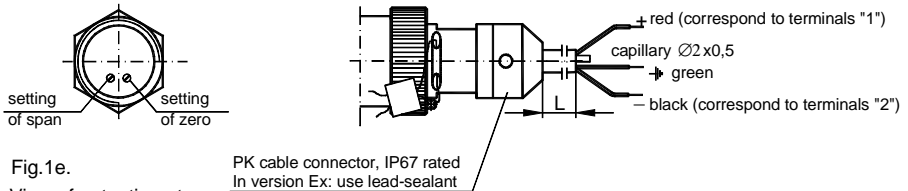

Fig.1e.
View of potentiometers
of zero and span
(PD, PK lub PM12)

Fig.1d. PCE-28 transmitter with PK connector
for output signal 4...20mA

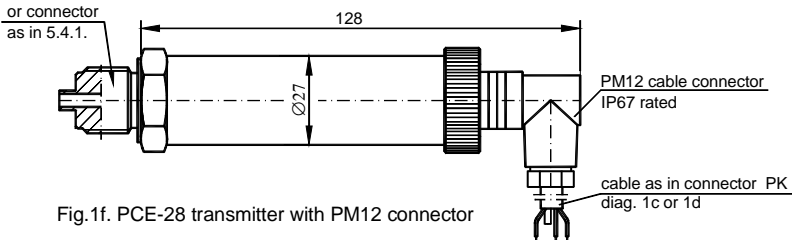
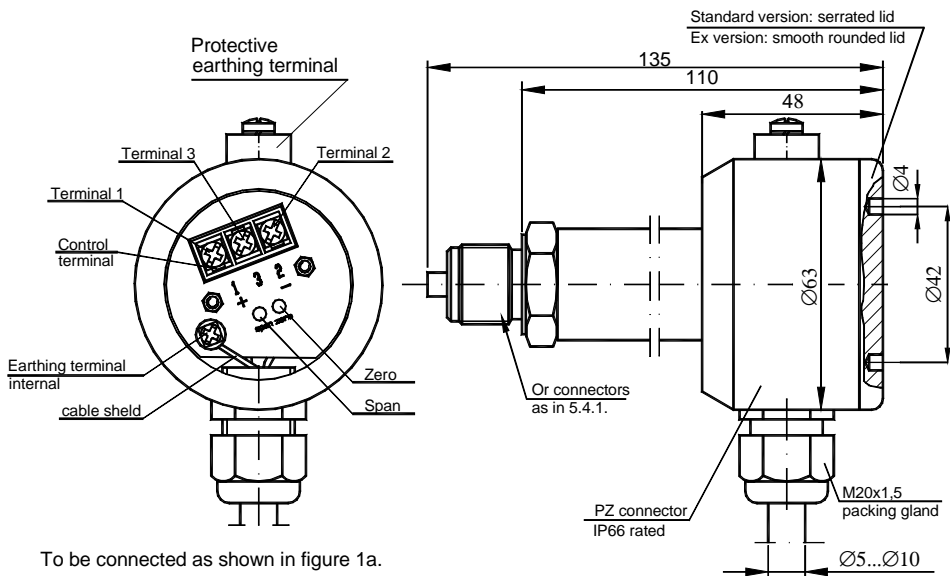

Fig.1f. PCE-28 transmitter with PM12 connector

Figure 1. PCE-28 transmitter with PD, PK and PM12 connectors: dimensions and methods of connection.



To be connected as shown in figure 1a.

Terminals designation to 4 ... 20mA output signal:

Terminal 1 - "+" (plus)
Terminal 2 - "-" (minus)
Terminal 3 - TEST_SIGNAL

To output current measure in the transmitter without the signalling circuit disconnecting, connect a multimeter to control terminals 1 and 3 (max. voltage fall on the milliammeter: 200mV).

Terminals designation to: 0 ... 20mA and 0 ... 10V output signals: "1" (+ supply), "2" (+ output signal),

Terminal 1 - "+" (plus)
Terminal 2 - "-" (minus)
Terminal 3 - TEST_SIGNAL

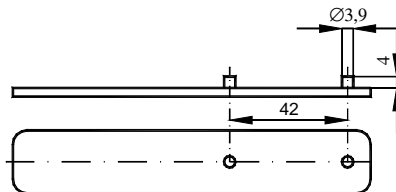

Tool used to screw down the lid of the PZ terminal box (for Ex version).

Figure 2. PCE-28 transmitter with PZ connector: dimensions and connection method.

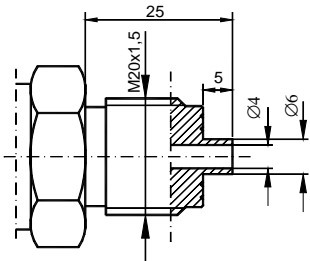

Fig.3a. M-type connector
with M20x1.5 thread

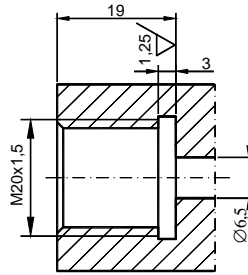

Fig.3b. Socket for M-type connector.

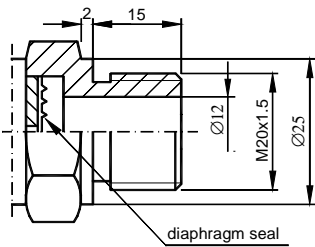

Fig.4a. P-type connector
with M20x1.5 thread

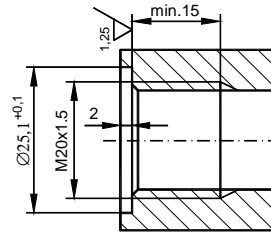

Fig.4b. Socket for P-type connector

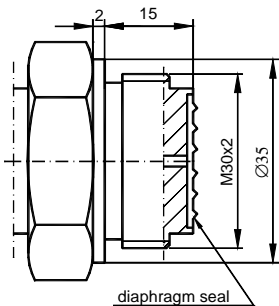

Fig.5a. CM30x2-type connector
with flush diaphragm
with M30x2 thread,

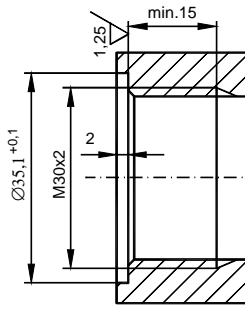

Fig.5b. Socket for
CM30x2-type
connector

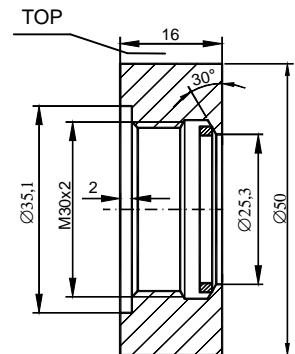

Fig.5c. Weldable fitting ring for
CM30x2-type connector
Sealing: teflon

Order code Socket CM30x2



The ring in Fig.5c must be welded in place with the word TOP upwards

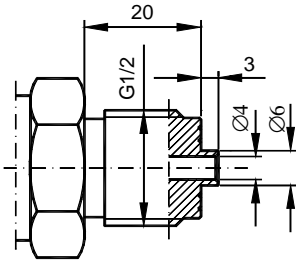

Fig.6a. G1/2-type connector with G1/2" thread

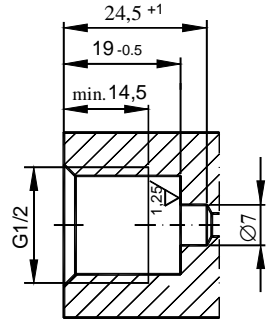

Fig.6b. Socket for G1/2-type connector.

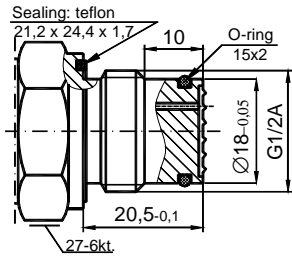

Fig.6c. CG1/2 -type connector with flush diaphragm with G1/2" thread,

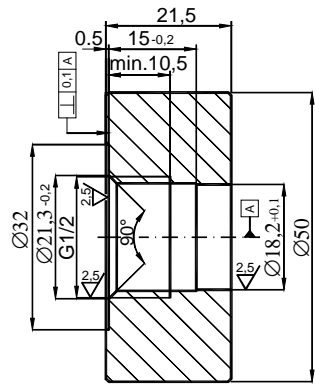

Fig.6d. Weldable fitting ring for CG1/2 - type connector
Order code Socket CG1/2

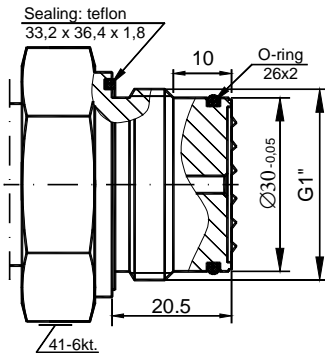

Fig.6e. CG1-type connector with flush diaphragm with G1" thread,

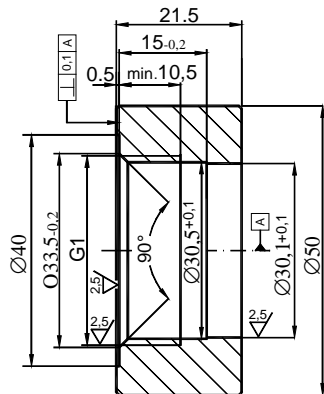

Fig.6f. Weldable fitting ring for CG1 - type connector
Order code Socket CG1

Figure 6. Process connections G1/2" and G1".

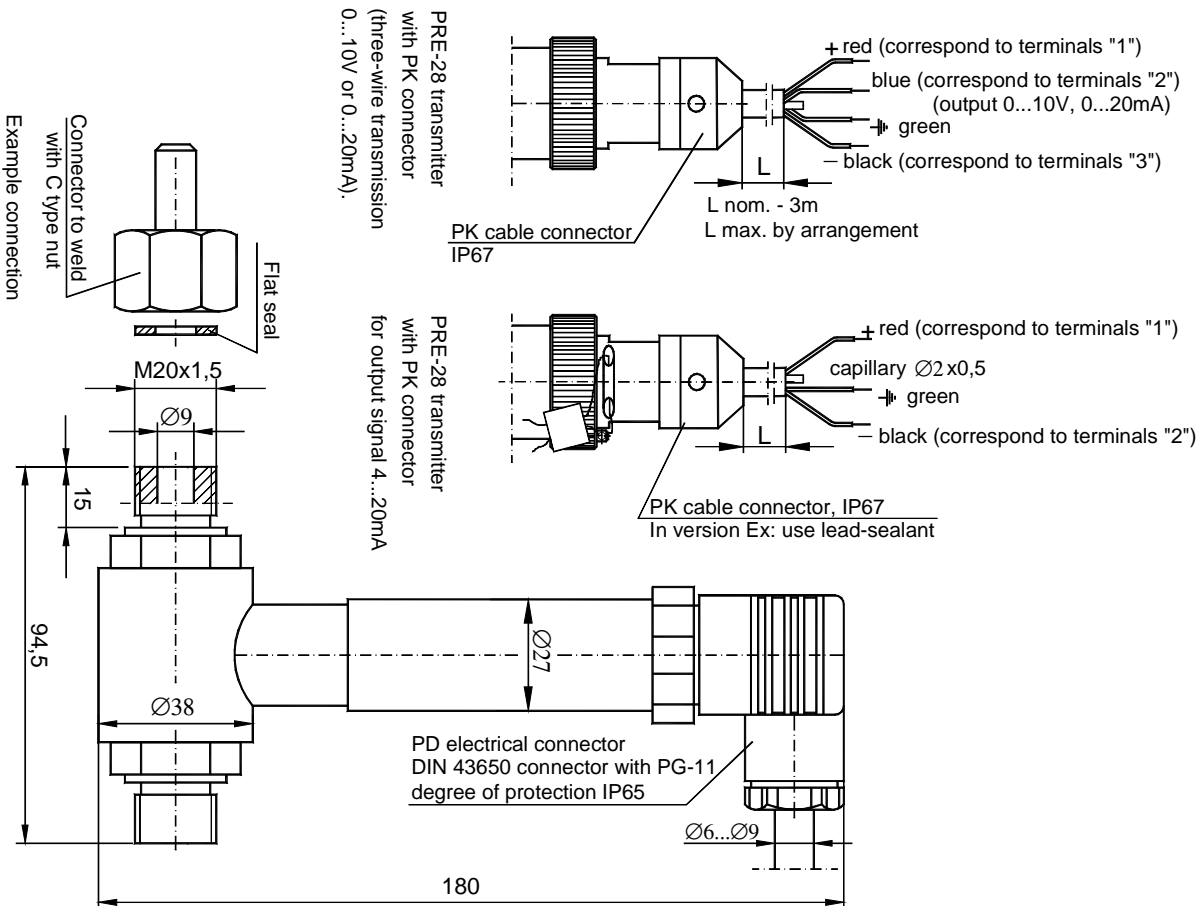

Figure 7. PRE-28 differential pressure transmitter with PD, PK connectors.

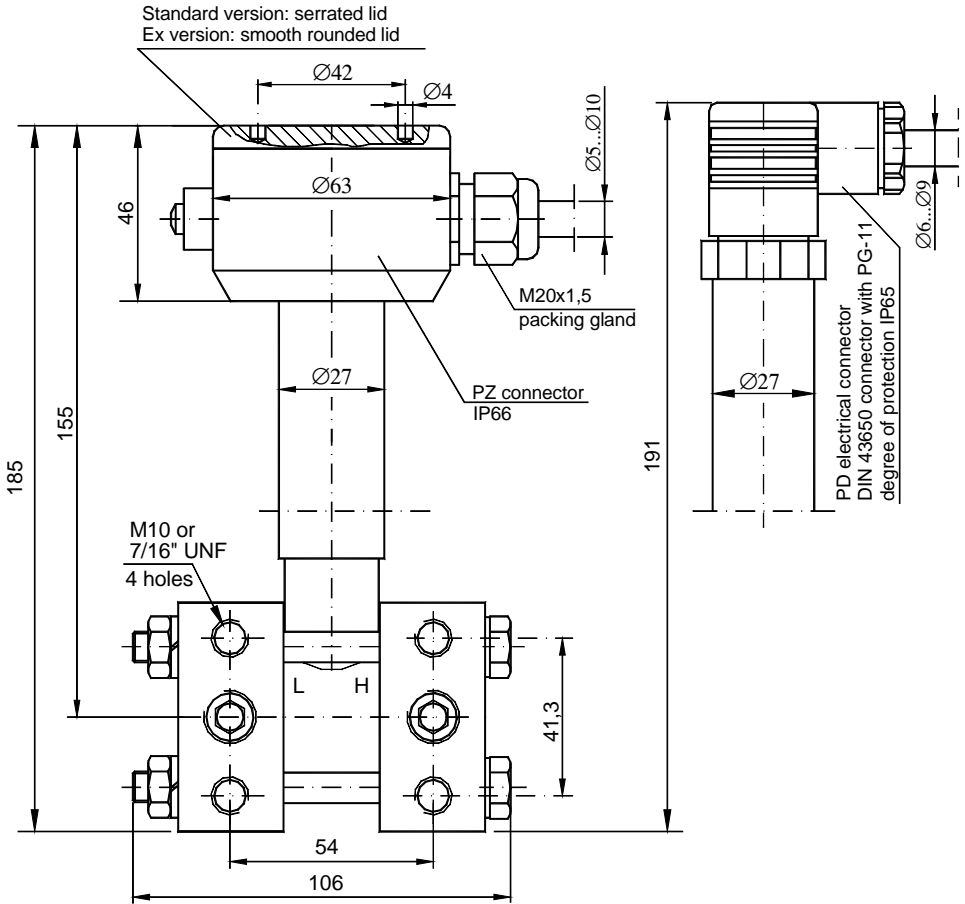

Figure 8. PRE-28 differential pressure transmitter with C-type process connection to be mounted together with valve manifold.

PCE-28P level probe

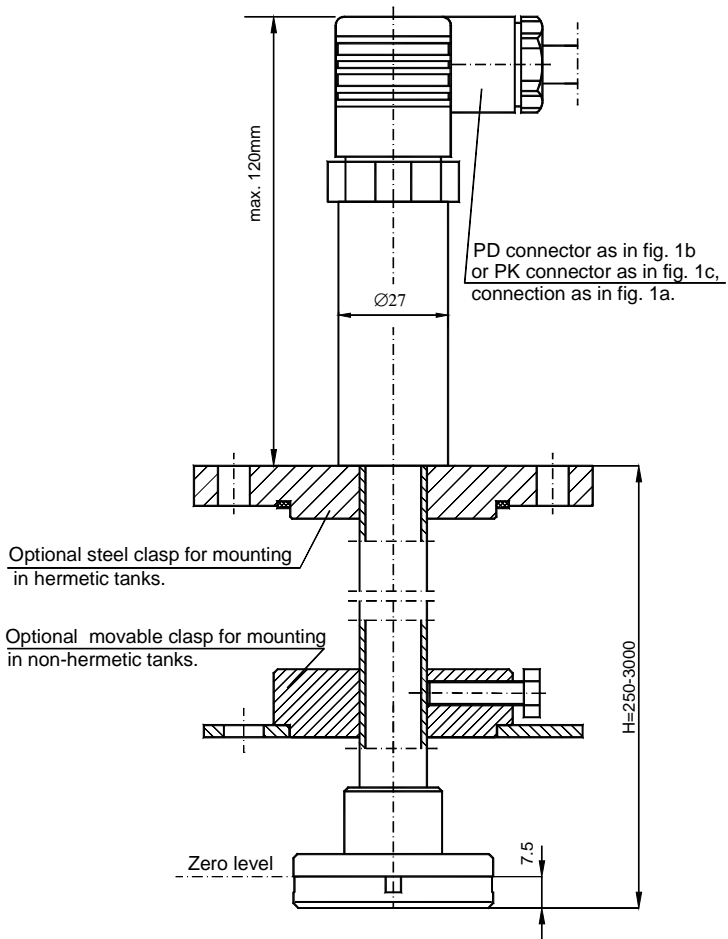

Figure 9. PCE-28P level probes

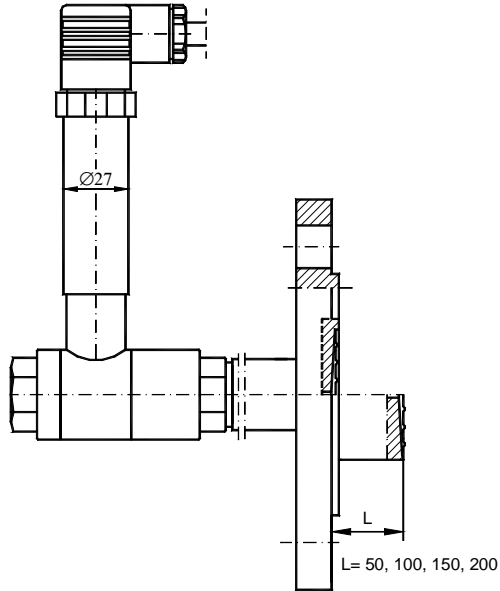

Figure 10. PRE-28 differential pressure transmitter with a single direct diaphragm seal

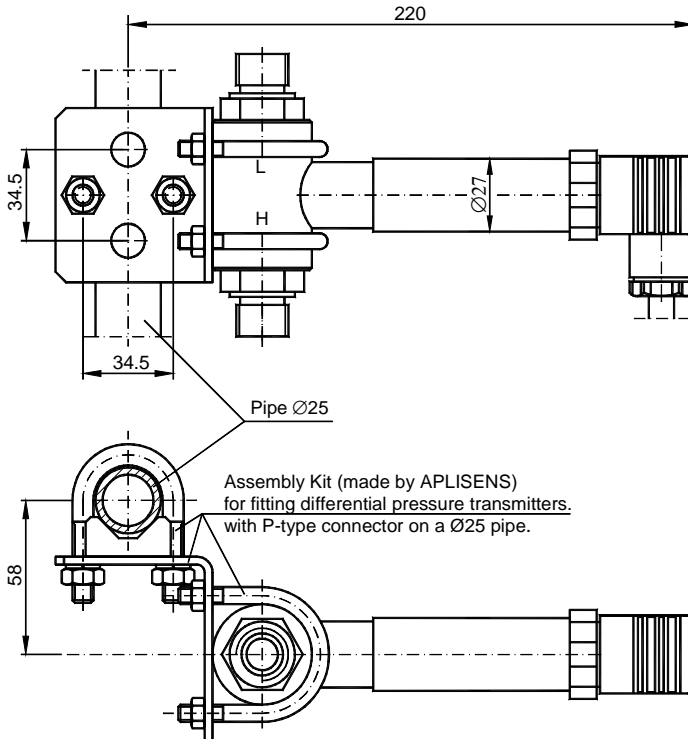

Figure 11. Example: how to install the PRE-28.

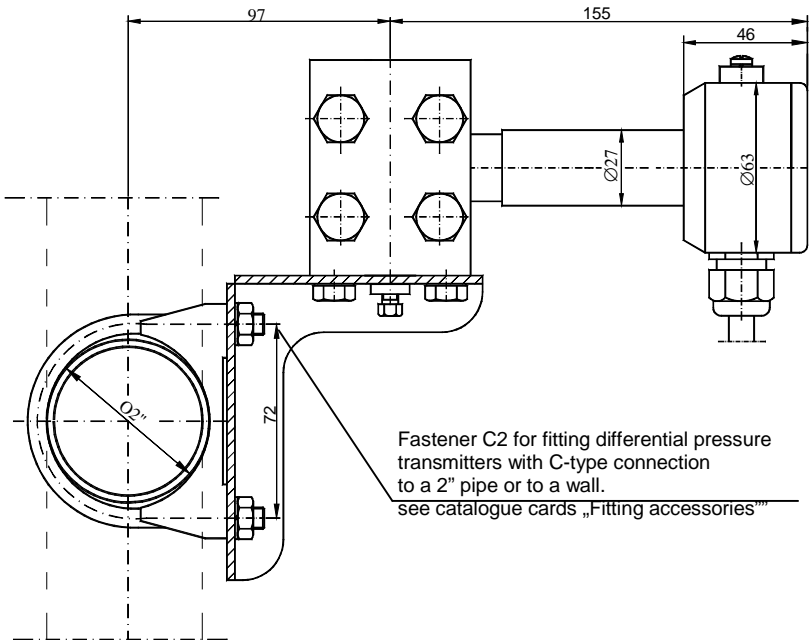

Figure 12. Example: how to install the PRE-28 transmitter on a vertical or horizontal pipe.

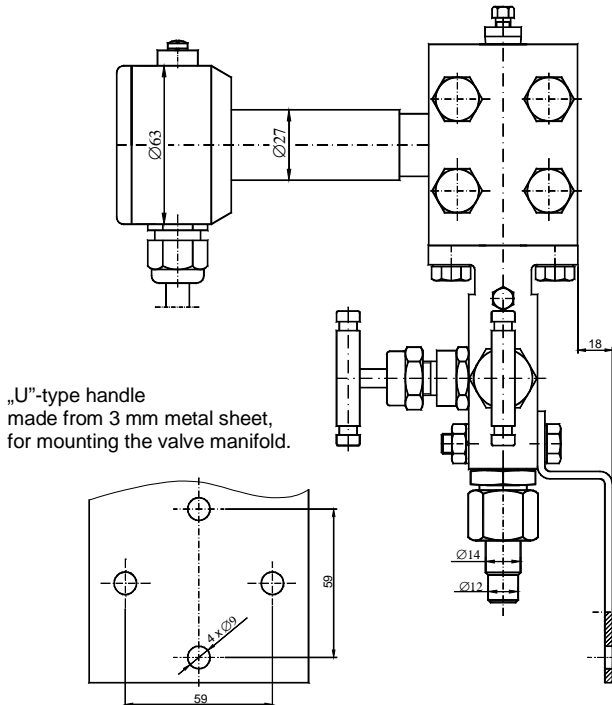

Figure 13. Example: how to install the PRE-28 transmitter with a valve manifold to a wall

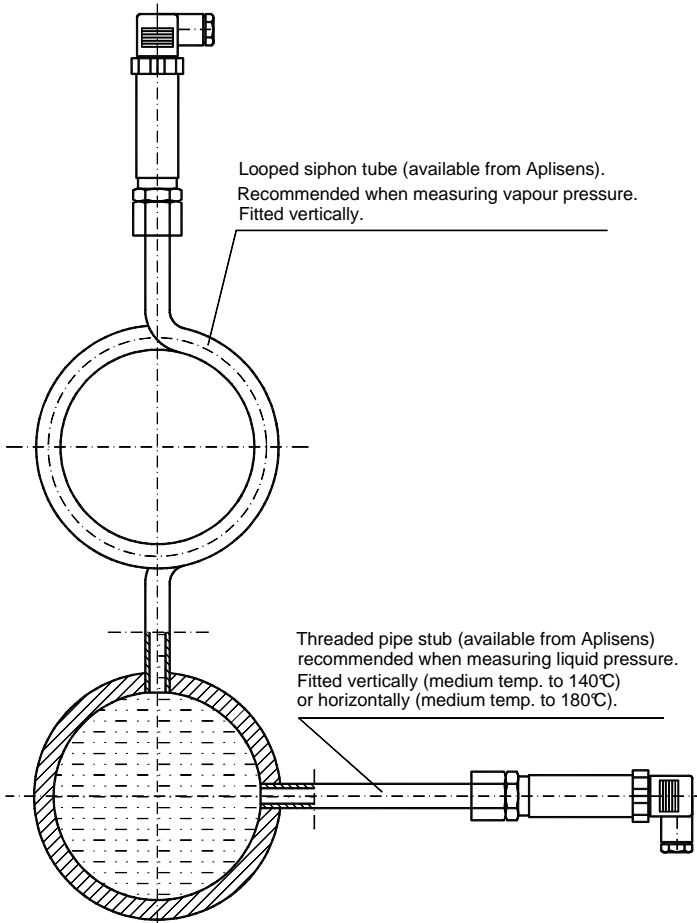

Figure 14. Possible methods of isolating the transmitter from high temperatures

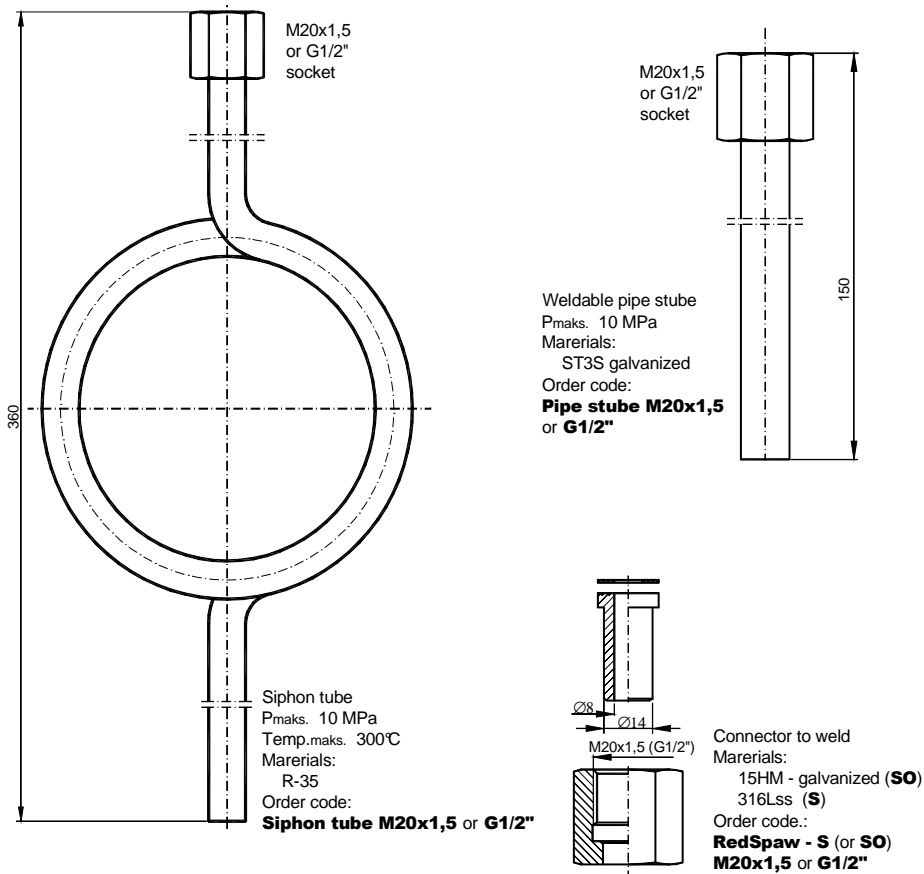

Figure 15. Additional equipment for fitting of pressure transmitters.